

Split 750



FROZEN ICE



Modular ice maker 400 kg - Scale system

• Position n°



• Application fields

Hotel	●●●●●●●●	Fish market	●●●●●●●●
Restaurant	●●●●●●●●	Supermarket	●●●●●●●●
Fast food	●●●●●●●●	SPA	●●●●●●●●
Bar	●●●●●●●●	Medical	●●●●●●●●
Disco	●●●●●●●●	Industry	●●●●●●●●

• Features & Plus

- Subcooled flakes (from -5°C to -10°C)
- Low consumption (1 liter water / 1 kg ice)
- AISI 304 SS Scotch Brite finish
- Evaporator AISI 304 Stainless Steel made, with rotating knife
- Cleanable antiscaling filter
- Easy cleaning thanks to rounded surfaces
- FDA approved -ABS plastic components
- Conformity to RoHS directive
- Automatic water charge
- Standard and special voltages
- Model in Tropical Class + 43 ° C
- 1 m³ = 430 kg of ice

• Usable Bins

- Bin T830
- Bin 1200DD
- RB 280

2 Years Warranty

subject to limitations

• Certifications available for this model



N.T.F. S.r.l. Nuove Tecnologie del Freddo

Via dell'Industria 10/B
20020 Villa Cortese (MI), Italy

tel. +39 0331 436217
fax +39 0331 436218

www.ntfice.it
info@ntfice.it



ntfice.it





Modular ice maker 400 kg - Scale system

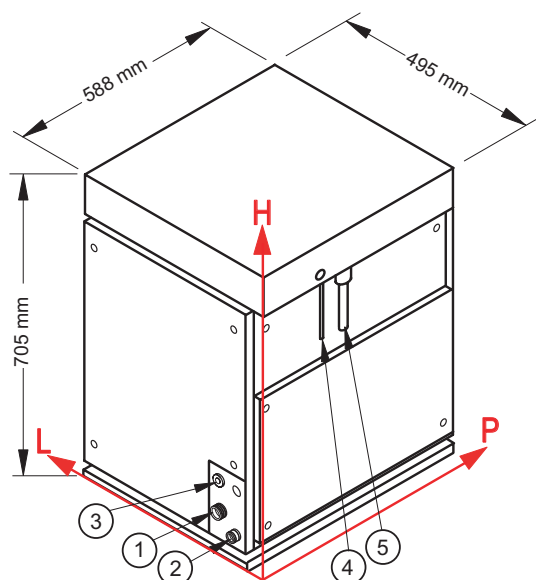

● Working conditions

- Location: Indoor

	Min	Max
Ambient temperature	+10° C	+43° C
Water temperature	+3° C	+32° C
Voltage	-10%	+10%
Water inlet pressure	1bar (14 psi)	6bar (84 psi)

● Technical information

Production in 24h	400 kg
Refrigerant	R404A - R507
Refrigerant capacity	2200 W (evap. temp. -23° C)
Standard voltage	220-240 V ~ 50 Hz
Electrical consumption	180 W
Sizes (L-P-H mm)	495 - 588 - 705
Sizes with pack (L-P-H mm)	550 - 655 - 900
Net weight	66 kg
Gross weight	82 kg
Finish	AISI 304 stainless steel, scotch brite

● Connections

All measures are referred to the rear bottom-left corner (L-H-Ø)

- ① Water inlet:
118 mm - 115 mm - 3/4"
- ② Water outlet:
68 mm - 60 mm - 24 mm
- ③ Electrical connection:
118 mm - 199 mm
- ④ Refrigerant feeding pipe
- ⑤ Outlet pipe of gaseous refrigerant

All the technical information must be considered at the following conditions:



Refrigerant capacity
2200 W
(evap. temp. -23° C)



Water temperature
+15° C



Electrical consumption
at +43° C
(standard voltage)

Models and specifications are subject to change without notice
Rev. 00 - Issued September 2016

